

# Dual Vespel® Ring Inlet Seals

**Trouble-Free, Leak-tight, & Highly Inert**

- Easy installation reduces operator variability.
- Prevent leaks—improve chromatography and increase column lifetime.
- Maintain a leak-tight seal, even after multiple oven cycles.



**Chromatography Products**

www.restek.com 800-356-1688 • 814-353-1300

Dear Valued Customer,

Choosing the right GC accessory for your application can be a challenge. Helping you select the right tool for your job is our job here at Restek. This article will introduce you to Restek's innovative Dual Vespel® Ring inlet seal and explain some of its key features and benefits.

Watch for more technical literature from Restek focusing on other GC accessories and how they can improve your analyses and simplify your work. Also, please take advantage of our comprehensive technical service by calling 800-356-1688, ext. 4, Monday through Friday, 8:00AM to 6:00PM (EST) or contact your local Restek representative. And, if I can personally help you, don't hesitate to ask.

Sincerely,

**Scott Grossman**  
GC Accessories Chemist



### A Critical Seal

In an Agilent split/splitless inlet, a critical seal is made between the bottom of the inlet body and the top of the inlet seal. This seal must be leak-free to maintain pressure and to prevent the air leaks that can compromise chromatography and shorten column lifetime. Traditionally, a lot of force was recommended to create this metal-to-metal connection, which caused installation variability among operators and a significant amount of wear and tear on the sealing edge of the inlet.

Restek's innovative Dual Vespel® Ring inlet seal solves both these problems and eliminates the need for a spacing washer, giving you a better seal with fewer parts (Figure 1). Because there is no metal-to-metal contact, the Dual Vespel® Ring seal requires much less torque to install, reducing variability among operators. The Vespel® ring on the bottom creates another leak-free point and functions as a spacing ring, eliminating the need for a washer. This seal is also more forgiving than a metal-to-metal seal; the soft Vespel® material will not damage the bottom of your inlet and it will seal more easily on inlets that have existing damage.

### Reliable, Leak-Tight Seals

The Dual Vespel® Ring inlet seal gives a much lower leak rate, with less torque required, than a conventional metal inlet seal (Figure 2). The seal is also exceptionally robust. While metal-to-metal connections are prone to leaking after multiple oven cycles, the Vespel® material maintains a leak-free seal—even after repeated heating cycles—without retightening the reducing nut (Figure 3).

### Inertness

Dual Vespel® Ring inlet seals are designed to minimize sample exposure. The outer edge of the inlet liner is within the boundaries of the Vespel® ring (Figure 4). Since the walls of the bottom of the liner are approximately 2 mm thick, the Vespel® material is well outside the flow path of the sample during split mode. In splitless mode, the sample may contact with the Vespel® material, however, the Vespel® material is chemically resistant and has a very low off-gassing profile. It is a polyimide-based polymer and is commonly used in ultra-high vacuum systems (e.g. lens insulators in some mass spectrometer sources) and in composite ferrules for inlets and mass spectrometer transfer lines, where leak-free seals and chemical inertness are critical.

**Figure 1** Vespel® rings on both the top and bottom surfaces simplify installation by reducing the torque requirement and eliminating the need for a washer.



**Figure 2** The Dual Vespel® Ring inlet seal achieves a lower leak rate at lower torque than the conventional metal inlet seal at 200°C.

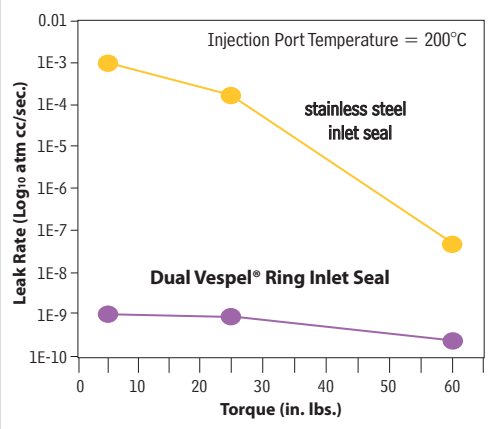

**Figure 3** Dual Vespel® Ring inlet seals remain leak-tight, even after repeated temperature cycles.

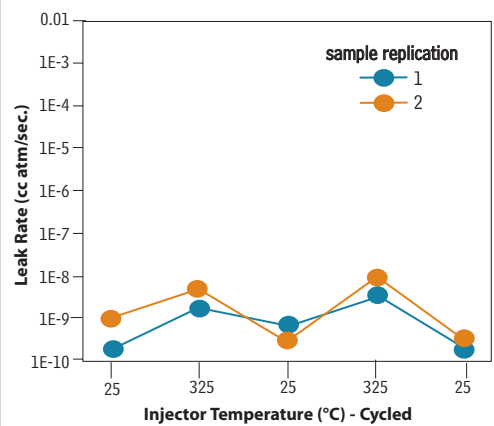

## Conclusion

Restek's Dual Vespel® Ring inlet seals offer a unique combination of performance and convenience. The soft Vespel® sealing surface improves the quality of the seal between the reducing nut and the inlet without damaging the critical seal at the bottom of the inlet. Additionally, the Vespel® ring on the bottom of the seal eliminates the need for a spacing washer, reducing necessary parts and simplifying installation.

Dual Vespel® Ring inlet seals are the best choice for simple, leak-tight seals. They are available in bare stainless steel for analysis of unreactive compounds, gold-plated seals for more sensitive compounds, and Siltek®-treated seals for the ultimate in inertness.

**Figure 4** Cutaway image of an Agilent split/splitless inlet focused on the relative position of the inlet liner to the Vespel® ring embedded in the top of the Dual Vespel® Ring inlet seal.

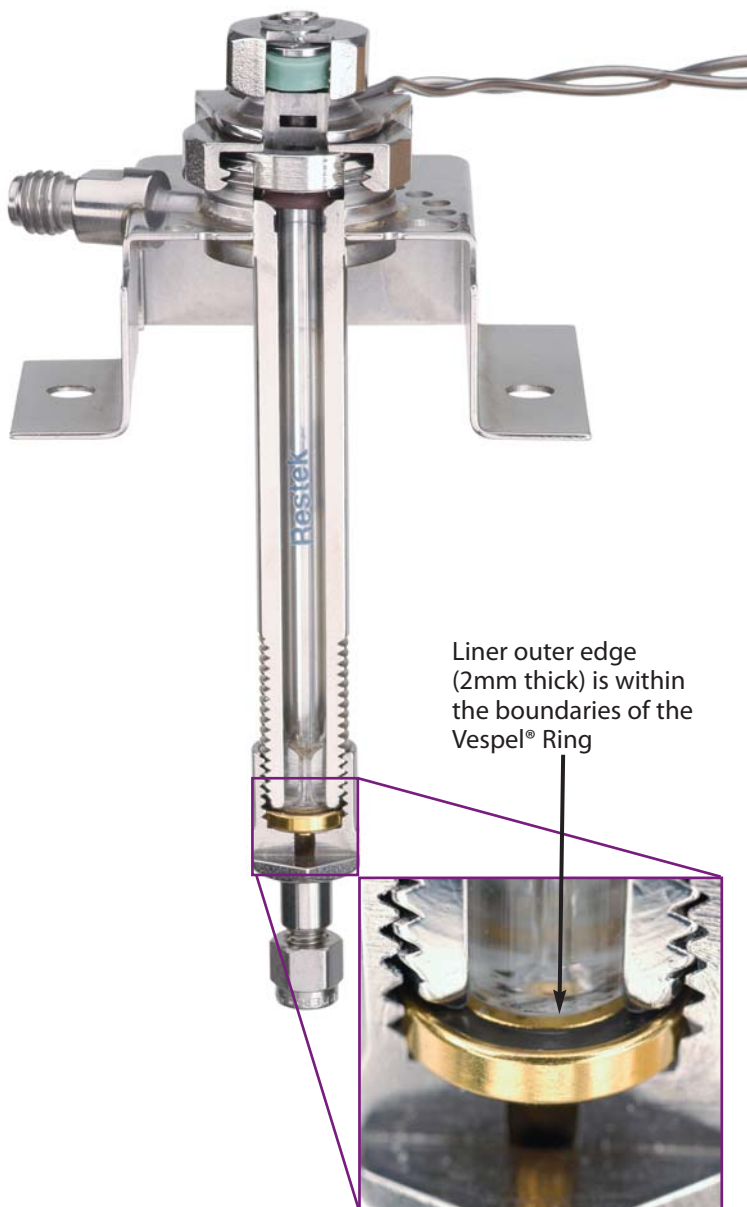

# The Risks of Reuse

While reusing inlet seals may be an appealing money-saving technique, it can decrease the lifetime of both the column and the inlet. When you reinstall an inlet seal in the reducing nut it isn't always seated in the same position and more torque is required to create another leak-tight seal. This creates overlapping channels which may cause air leaks, introducing oxygen into a hot column and shortening column lifetime. Using new seals at each installation is far less costly than having to replace your column or inlet prematurely due to damage from over-tightening or leaks that could have been prevented.

**Figure 1** Reusing an inlet seal creates overlapping channels and increases the probability of air leaks forming, which can significantly shorten column lifetime.

## After First Installation

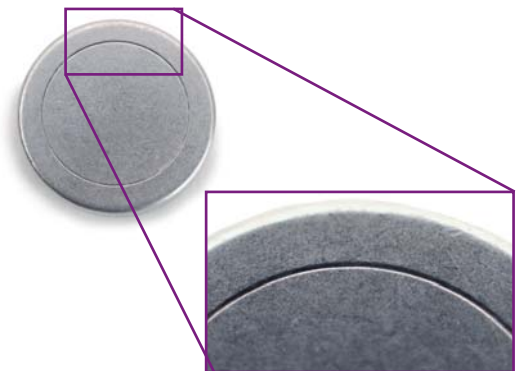

## After Second Installation

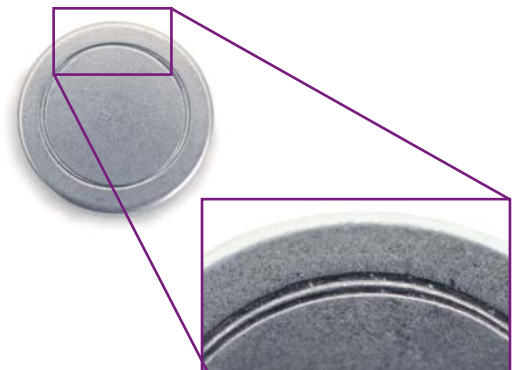



### Dual Vespel® Ring Inlet Seals

- Vespel® ring embedded in bottom surface eliminates need for washer.
- Vespel® ring embedded in top surface reduces operator variability by requiring minimal torque to seal.
- Prevents oxygen from permeating into the carrier gas, increasing column lifetime.

#### Washerless, leak-tight seals for Agilent 5890/6850/6890/7890 GCs

0.8mm ID Dual Vespel® Ring Inlet Seal	2-pk.	10-pk.
Gold-Plated	21240	21241
Siltek® Treated	21242	21243
Stainless Steel	21238	21239
1.2mm ID Dual Vespel® Ring Inlet Seal	2-pk.	10-pk.
Gold-Plated	21246	21247
Siltek® Treated	21248	21249
Stainless Steel	21244	21245

Dual Vespel® Ring inlet seals are available in gold plating, stainless steel, and Siltek® treated.



Patent pending.



**Small, compact unit—easy to hold and operate.**

### Restek Electronic Leak Detector

- Reliable thermal conductivity leak detector.
- Responds to leaks in less than 2 seconds.
- Audible alarm plus LED readout.
- Auto zeros with the touch of a button.
- Built-in rechargeable 9-volt battery.

#### Leak Detector Facts

Detectable gases:	helium, nitrogen, argon, carbon dioxide
Battery:	Rechargeable Ni-MH, 9 volt
Operating	
Temperature Range:	32°-120°F (0°-48°C)
Humidity Range:	0-97%
CE Approved:	Yes



Easy-to-clean probe assembly

Description	qty.	cat.#
Leak Detector with 110Volt Battery Charger	ea.	22451
Leak Detector with 220Volt European Battery Charger	ea.	22451-EUR
Leak Detector with 220Volt UK Battery Charger	ea.	22451-UK

Caution: The Restek Electronic Leak Detector is NOT designed for determining leaks of combustible gases. A combustible gas detector should be used for determining combustible gas leaks under any condition. The Restek Electronic Leak Detector may be used for determining trace amounts of hydrogen in a GC environment only.

Restek Trademarks: Restek logo, Siltek.

Other Trademarks: Vespel (E.I. du Pont de Nemours & Co., Inc.)

**Restek Corporation**  
110 Benner Circle  
Bellefonte, PA 16823-8812

Presorted Standard  
US Postage  
PAID  
Restek



Lit. Cat.#580186

© 2007 Restek Corporation.

**Restek U.S.** • 110 Benner Circle • Bellefonte, PA 16823 • 814-353-1300 • 800-356-1688 • fax: 814-353-1309 • [www.restek.com](http://www.restek.com)

**Restek France** • phone: 33 (0)1 60 78 32 10 • fax: 33 (0)1 60 78 70 90 • e-mail: [restek@restekfrance.fr](mailto:restek@restekfrance.fr)

**Restek Ireland** • phone: 44 2890 814576 • fax: 44 2890 814576 • e-mail: [resteurope@aol.com](mailto:resteurope@aol.com)

**Thames Restek U.K. LTD** • phone: 44 1494 563377 • fax: 44 1494 564990 • e-mail: [sales@thamesrestek.co.uk](mailto:sales@thamesrestek.co.uk)

**Restek GmbH** • phone: +49 (0) 6172 2797 0 • fax: +49 (0) 6172 2797 77 • e-mail: [info@restekgmbh.de](mailto:info@restekgmbh.de)

